

# DP TECHNICS

**DPT-Module**  
Datasheet

## 1 General information

The DPT-Module is a general purpose embedded system with integrated 2.4GHz 802.11n WiFi. This module is targeted for hobby and semi-professional applications in need of a powerfull embedded linux platform. OpenWRT is installed by default and the module is compatible with the AR9331 trunk versions of this software.

## 2 Features

The DPT-Module has a typical power consumption of 0.36W@3.3V and contains a number of features:

- CPU: AR9331 400MHz SoC - MIPS24Kc CPU
- RAM: 64MiB (512Mbit) DDR2
- Flash: 16MiB Flash memory
- WiFi: 150Mbps WiFi g/n with on-board antenna
- USB 2.0 master interface
- 20 GPIO pins
- 2 times 100Mbps ethernet ports
- UART interface
- SPI interface

## 3 Absolute maximum ratings

For the most reliable use and stability of the module we advice to use the typical ratings. We do not guarantee the correct functioning of the device outside the minimum and maxium range of the module.

Parameter	Units	Minimum rating	Typical rating	Maxium rating
DC Supply Voltage	V	3.0	3.3	3.6
Digital I/O Voltage	V	1.5	2.50	2.62
Current	A	0.09	0.110	0.350
Network transformer voltage	V	1.9	2.2	2.3

## 4 Pin diagram

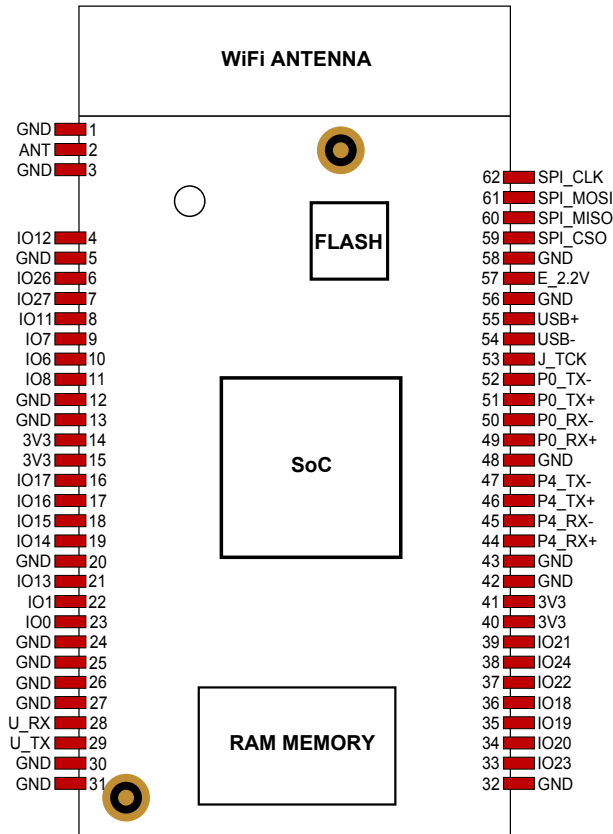

## 5 Pin descriptions

Pin	Name	Input/Output	Description
1	GND	input	GND connection
2	ANT	bidirectional	External antenna connector
3	GND	input	GND connection
4	GPIO12	bidirectional	I/O line number 12 (floating)
5	GND	input	GND connection
6	IO26	bidirectional	I/O line number 26 (floating)
7	IO27	output	System LED 1K series output positive
8	IO11	input	1K and 100pF input, reset if connected with GND
9	IO7, JTAG.TDO	output	10K pull-down output
10	IO6, JTAG.TDI	output	10K pull-down output
11	IO8, JTAG.TMS	output	10K pull-down output
12	GND	input	GND connection
13	GND	input	GND connection
14	3V3	input	Supply voltage pin (recommended with pin 15)
15	3V3	input	Supply voltage pin (recommended with pin 14)

Pin	Name	Input/Output	Description
16	IO17	output	10K pull-up output
17	IO16	bidirectional	10K pull-down output
18	IO15	bidirectional	10K pull-down output
19	IO14	bidirectional	10K pull-down output
20	GND	input	GND connection
21	IO13	output	10K pull-up output
22	IO1	output	10K pull-up output
23	IO0	output	10K pull-down output
24	GND	input	GND connection
25	GND	input	GND connection
26	GND	input	GND connection
27	GND	input	GND connection
28	U_RX	input	UART receive connection
29	U_TX	output	UART transmit connection
30	GND	input	GND connection
31	GND	input	GND connection
32	GND	input	GND connection
33	IO23	bidirectional	I/O line number 23
34	IO20	bidirectional	I/O line number 20
35	IO19	bidirectional	I/O line number 19
36	IO18	bidirectional	I/O line number 18
37	IO22	bidirectional	I/O line number 22
38	IO24	bidirectional	I/O line number 24
39	IO21	bidirectional	I/O line number 21
40	3V3	input	Supply voltage pin
41	3V3	input	Supply voltage pin
42	GND	input	GND connection
43	GND	input	GND connection
44	P4_RX+	input	LAN port 4 positive RX connection, default WAN port
45	P4_RX-	input	LAN port 4 negative RX connection, default WAN port
46	P4_TX+	input	LAN port 4 positive TX connection, default WAN port
47	P4_TX-	input	LAN port 4 negative TX connection, default WAN port
48	GND	input	GND connection

<b>Pin</b>	<b>Name</b>	<b>Input/Output</b>	<b>Description</b>
49	P0_RX+	input	LAN port 0 positive RX connection
50	P0_RX-	input	LAN port 0 negative RX connection
51	P0_TX+	input	LAN port 0 positive TX connection
52	P0_TX-	input	LAN port 0 negative TX connection
53	J_TCK	output	JTAG Test Clock connection
54	USB-	bidirectional	USB negative data connection
55	USB+	bidirectional	USB positive data connection
56	GND	input	GND connection
57	E_2.2V	output	ethernet transformer bias voltage
58	GND	input	GND connection
59	SPI_CSO	output	SPI slave select output
60	SPI_MISO	input	SPI Master In Slave Out (MISO) connection
61	SPI_MOSI	output	SPI Master Out Slave In (MOSI) connection
62	SPI_CLK	output	SPI clock connection

## 6 Mechanical information

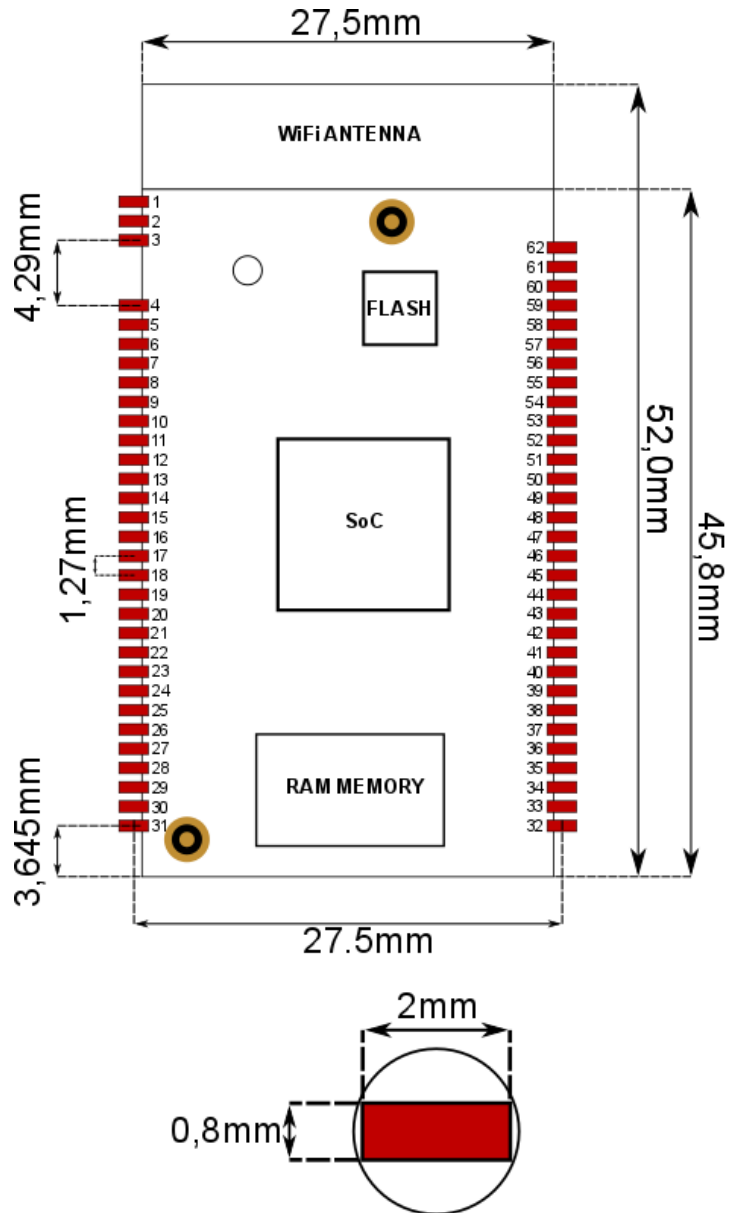

## 7 Power supply recommendations

All the 3V3 and GND pins are interconnected on the board but it is recommended to use more than one of these pins to give power supply to the module. It is sufficient to use pin 14 and 15 for feeding the supply voltage. Please use 100nF ceramic capacitors for decoupling.

## 8 GPIO ports

The GPIO ports are not 3.3V resistant and you must use a voltage divider circuit if you want to connect a 3.3V or 5V circuit to one of the GPIO pins.

## 9 Software

The module comes with the OpenWRT Linux distribution preflashed and with the handy LuCi webinterface installed in the distribution. We will continue to release new software which you can download from <http://www.dpstechnics.com>.

## 10 Operating conditions

The module can operate in a wide range of temperatures and conditions. The following are guidelines in which the module is guaranteed to work correctly.

Parameter	Units	Minimum rating	Typical rating	Maxium rating
Working temperature	°C	0		40
Storage temperature	°C	-40		70
Humidity	%RH	10		90
Storage humidity	%RH	5		90

Please note that no condensation may occur on the PCB and components.

## 11 Legal information

This module is distributed worldwide by DPTechnics. We are not responsible for any product this module is part of. This datasheet is made with great care for detail but it can be possible the datasheet will be updated with more accurate data in the future. Users of DPTechnics products can contact us by letter, telephone or email.

DPTechnics  
Westkapellestraat 396/44  
8300 Knokke-Heist  
Belgium

Tel: +32(0)50 62 13 79  
email: [info@dptechnics.com](mailto:info@dptechnics.com)  
web: <http://www.dptechnics.com>